

TRAILER ESTATES PARK & RECREATION DISTRICT

BOARD OF TRUSTEES WORKSHOP

December 4, 2023

**MARK'S HALL
TRAILER ESTATES
1903 69TH AVENUE WEST
BRADENTON, FLORIDA 34207**

Call To Order
Roll Call
Public Input (Limit 3 Minutes on Workshop Agenda Items only)
Reports from Standing Committees
Clubs & Organizations

Discussion Items Presented by Board & Staff (PP38)

ADA Pool Access Project (Lombardi)
Install 3 RV Monitors Throughout Trailer Estates w/732 Displayed (Morris)

Trustee Reports

Violation Report - No Action Required

1. Violation Summary

Park Manager Comments
Unfinished Business
Adjournment

Trailer Estates broadcasts its Meeting live on Channel 732 inside the Community
Zoom Meeting Access: Time: December 4, 2023 09:30 AM Eastern Time (US and Canada)
Trailer Estates broadcasts its Meeting live on Channel 732 inside the Community

Join Zoom

Meeting <https://us02web.zoom.us/j/83168307792?pwd=RG1hZ3psVHFQTXkwZ1M1SXJVMkhtUT09>

Meeting ID: 831 6830 7792

Passcode: 6nuBq5

Meeting ID: 831 6830 7792

Passcode: 929963

Dial by your location

• +1 305 224 1968 US • +1 646 931 3860 US

Find your local number: <https://us02web.zoom.us/u/kbwM31xKEa.c>

Pursuant to Section 286.0105, Florida Statutes, should any person wish to appeal a decision of the Board with respect to any matter considered at this meeting, he or she will need to ensure that a verbatim record of the proceedings is made, including the testimony and evidence upon which the appeal is to be based.

Pursuant to Section 286.26, Florida Statutes, and the Americans With Disabilities Act, any handicapped person desiring to attend this meeting should contact TJ Miller at 756-7177, at least 48 hours in advance of the meeting, to ensure that adequate accommodations are provided for access to the meeting.

TRAILER ESTATES PARK AND RECREATION DISTRICT
BOARD AGENDA ITEM FORM PP 38

DUE IN OFFICE 10:30 A.M. MONDAY PRIOR TO MEETING THAT YOU WISH TO BRING ITEM FORWARD.

Agenda ADA Pool Access Project

For Upcoming Meeting—Date December 4, 2023

Type of Meeting (check one): Workshop Board Meeting

***It is recommended that Board Meeting Motions be an agenda item on a Workshop prior to the Board Meeting and the date or dates of the workshop discussions be included in the motion.**

Rationale (for workshops)/ MOTION (for board meetings): _____

Continuing Discussion on ADA Pool Access Project.

Costs/Estimated Costs: (Required if agenda item includes spending district money.)
Project Cost \$75,000

Attachments: (Please attach any diagrams or pertinent information concerning this
Agenda Item. Please list the attachments.) _____

Trustee Todd Lombardi

Date Submitted 11/3/2023

Chairman/Designee Tonia A. Nichols

Office Manager/Designee: Date Posted 11/27/2023 Initials [Signature]

Trailer Estates ADA Pool Access Quote summery

	Pool Lift	Hot tub lift	Platform Lift	Total
Mobility Plus	No Quote No longer doing commercial installations			0.00
101 Mobility	\$6,998.00	\$6,998.00	\$29,825.00	\$43,821.00
P&A Mobility Enterprises, Inc	No quote on this project			
Blue Edge Builders	No Quote No longer doing commercial installations			
Backup batteries				\$630.00
Concrete Work				3,850.00
ADA Doors openers Estimate by Nabco				7,106.44
Paxton Fob control				2,673.99
Gate and fence upgrades				8,500.00
Electrical additions				2,500.00
Possible electrical needs				5,000.00

Project Cost Total Required

\$74,081.43

TRAILER ESTATES PARK AND RECREATION DISTRICT
BOARD AGENDA ITEM FORM

PP 38

NOV 27 '23 AM 7:40

DUE IN OFFICE 10:30 A.M. MONDAY PRIOR TO MEETING THAT YOU WISH TO BRING ITEM FORWARD.

Agenda Install 3 TV Monitors Throughout Trailer Estates w/732 Displayed
For Upcoming Meeting—Date December 4, 2023

Type of Meeting (check one): Workshop Board Meeting

***It is recommended that Board Meeting Motions be an agenda item on a Workshop prior to the Board Meeting and the date or dates of the workshop discussions be included in the motion.**

Rationale (for workshops)/ MOTION (for board meetings): In order to keep
residents aware of the goings-on here at Trailer Estates, we propose to mount TV
monitors at: Breezeway by Office, Post Office, Entrance to Activity Center.
These would be attached to a cable box so that Community Channel 732 would rotate
continuously on these monitors.

Costs/Estimated Costs: **(Required if agenda item includes spending district money.)**
\$3500+/- Depending on Size of TV

Attachments: **(Please attach any diagrams or pertinent information concerning this**
Agenda Item. Please list the attachments.) 2 Types of outdoor enclosures
Various TV's

Trustee Park Manager Morris 

Date Submitted 11/22/23

Chairman/Designee Louis A. Nichols

Office Manager/Designee: Date Posted 11/27/2023 Initials 

NOV 27 '23 8:41

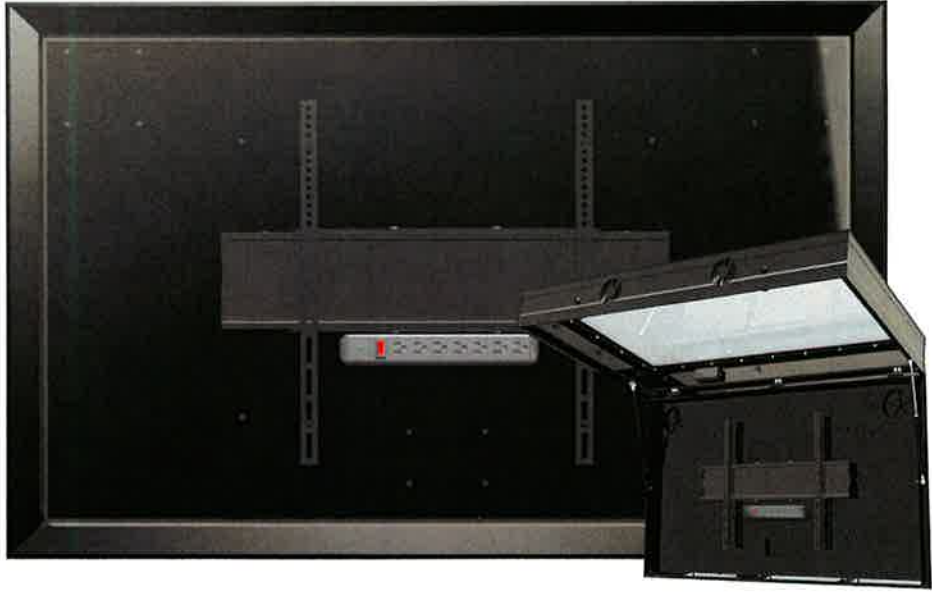

- ***Owner's Manual***
- ***Assembly Instructions***
- ***Warranty Information***

Manufacturer: Protective Enclosures Company
 277 Douglas Avenue, Suite 1012
 Altamonte Springs, Fl. 32714
 1-800-331-2628
 info@protectiveenclosures.com
www.thetvshield.com

Save this assembly manual for future reference in the event that you need to order replacement parts.



PARTS IDENTIFICATION

Included in Box

NDU 27 '23 an7:41



A. (1) Front Frame

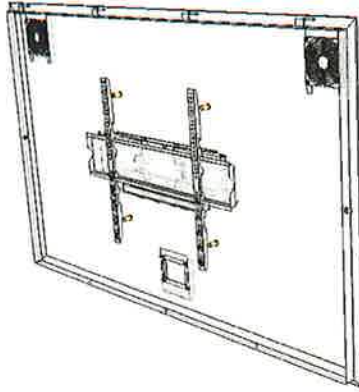

B. (1) Base Plate

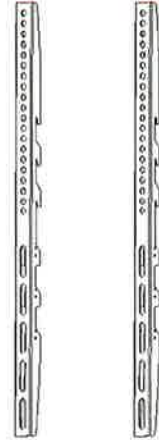

C. (2) Internal Mount Brackets

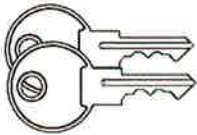

D. (2) Keys

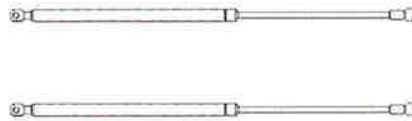

E. (2) Gas Shocks



F. (2) 1/4" E-Clips



G. (3) 3/16" E-Clips (or (4) 3/16" E-Clips with all units above 42-50")



H. (4) 1" x 0.90" Nylon Spacers (used for flush mounting)

See Remaining Parts Identification Items on the Next Page



DeerTV 50" - 55" Outdoor TV Enclosure Weatherproof Protection TV Case

31 Reviews

~~\$1,600.00~~ **\$828.88**

Sku: deertv55-fa

Product Type: Outdoor TV Enclosure

COOLING FAN: NO FAN WITH FAN

WINDOWS: ANTI-GLARE ACRYLIC CLEARLY ACRYLIC NO ACRYLIC (SELF-PROVIDED)

- 1 + [ADD TO CART](#)

[BUY IT NOW](#)



NOV 27 '23 AM 7:41

High Dynamic Range Format

HLG, HDR 10

Assembled Product Dimensions (L x W x H)

48.10 x 9.90 x 30.80 Inches

Warranty

Warranty information

1 Year Limited Warranty

Black Friday deal



+ Add

\$298.00

SAMSUNG 55" Class TU690T Crystal UHD 4K Smart Television - UN55TU690TFXZA (New)

★★★★★ 1517

2-day shipping



+ Add

Sponsored

\$328.00

LG 50" Class 4K UHD 2160P webOS Smart TV - 50UQ7070ZUE

★★★★★ 1534

Pickup Delivery 2-day shipping

Best seller



+ Add

Sponsored

Now \$178.00 ~~\$195.00~~

Hisense 43" Class 1080p FHD LED Roku Smart TV H4C

★★★★★ 2115

Pickup Delivery 2-day shipping

Early access



Now \$3,588.00 ~~\$4,000.00~~

Sony 85" Class BRAVIA XR X95K 4K HDR Mini LED with Smart Google TV XR85X95K- 2022 Model

★★★★★

Early access



Sponsored

Now \$3,888.00 ~~\$4,000.00~~

Sony XR83A90J 83" A90J Series BRAVIA XR OLED 4K UHD Smart TV with Dolby Vision HDR (2021)

★★★★★ 219

Early access



Now \$799.00 ~~\$899.00~~

SAMSUNG 50" Class 4K (2160P) The Frame QLED Smart TV

★★★★★ 609

Warnings

California State Chemical Warning Text

None

WARNING: WARNING: Reproductive Harm - www.P65Warnings.ca.gov



Earn \$17.40 on this item. See if you're pre-approved with no credit risk. Learn more

4.5 out of 5

★★★★★ (1269 reviews)

See all reviews

Write a review



Most helpful positive review

★★★★★ Verified Purchase

Very happy

Wonderful television. Couldn't be happier. We can get over 250 free channe's via Samsung TV PLUS that is built into the unit. We also install ROCKU (less than \$30.00) so we have access to thousands of programs, all fee! No more cable bills.

Most helpful negative review

15 customers found this helpful

☆☆☆☆ Verified Purchase

Terrible customer service in electronics

Make sure they don't sell you a used TV we got home and it had a Family pictures on it and somebody else's email and now I have to drive it all the way back and they are not being very helpful and this is their fault

VS

Violation Summary

Trailer Estates Park & Recreation District

09/14/2023 - 11/22/2023

Prepared by
Trailer Estates Park & Recreation District

Top Violations By Category

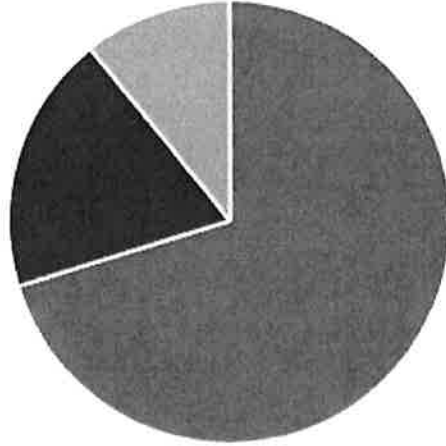

Property Maintenance - Deed Restrictions (26) Article - Motorhomes, Campers, Boats and T... (7)
Deed Restriction Article 11 & 12 (4)

1817 OHIO AVE Bradenton, FL
BEAUCHAMP BERYL D

1 Violation

 09/14/2023 @ 10:50AM

Property Maintenance - Deed Restrictions: Building Repairs Required

Inspector Comment: Replace skirting on front of trailer ASAP

1st Occurrence

[view in dashboard >](#)

1906 MINNESOTA AVE Bradenton, FL
CERMAK JOHN

3 Violations

 11/22/2023 @ 9:00AM

3rd Occurrence

Article - Motorhomes, Campers, Boats and Trailers: No Derelict Vehicles

Inspector Comment: Third violation, spoke with homeowner and asked for registrations to satisfy the issue, and they have not been brought in as of this date

[view in dashboard >](#)

 11/15/2023 @ 9:38AM

2nd Occurrence

Article - Motorhomes, Campers, Boats and Trailers: No Derelict Vehicles

Inspector Comment: Second notice no progress has been made to satisfying first violation, remove derelict vehicles from property

[view in dashboard >](#)

 10/27/2023 @ 9:50AM

1st Occurrence

Article - Motorhomes, Campers, Boats and Trailers: No Derelict Vehicles

Inspector Comment: Remove derelict vehicles

[view in dashboard >](#)

6616 NEW JERSEY ST Bradenton, FL
CUMMINS CAROLE SUE

1 Violation

 Open 11/22/2023 @ 9:25AM

1st Occurrence

Property Maintenance - Deed Restrictions: Trim Trees, Bushes and/or Shrubs

Inspector Comment: Trim bushes on the side of carport

[view in dashboard >](#)

6517 MASSACHUSETTS ST Bradenton, FL
JENKINS RICHARD T

3 Violations

 10/11/2023 @ 9:36AM

2nd Occurrence

Property Maintenance - Deed Restrictions: Grass, Weeds, Vegetation in Gravel/Paved/Paver Blocks

Inspector Comment: It appears no work has been done since first notice, we are now issuing second violation

[view in dashboard >](#)

 09/27/2023 @ 9:58AM

1st Occurrence

Property Maintenance - Deed Restrictions: Grass, Weeds, Vegetation in Gravel/Paved/Paver Blocks

Inspector Comment: Spray and remove weeds and vegetation and gravel areas

[view in dashboard >](#)

 09/27/2023 @ 9:58AM

1st Occurrence

Property Maintenance - Deed Restrictions: Mold, Dirt, and/or Algae on Buildings or Fences

Inspector Comment: Power wash, and or paint trailer as needed, please pay attention to front awning

[view in dashboard >](#)

2004 INDIANA AVE Bradenton, FL
LAMMERS SIDNEY GARY III

1 Violation

 11/22/2023 @ 10:21AM

1st Occurrence

Article - Motorhomes, Campers, Boats and Trailers: Motorhomes, Campers, Boats and Trailers on Property illegally Parked

Inspector Comment: Pull or spray weeds, and gravel areas

[view in dashboard >](#)

6624 CALIFORNIA ST Bradenton, FL
LUCAS MICHAEL P

1 Violation

 11/22/2023 @ 9:59AM

1st Occurrence

Deed Restriction Article 11 & 12: RV/utility trailer/camper or other vehicles/equipment stored in public view

Inspector Comment: No trailers allowed on property. It was completely storage underneath the carport.

[view in dashboard >](#)

6613 ARIZONA ST Bradenton, FL
MILLS EVE S

1 Violation

 11/08/2023 @ 9:36AM

1st Occurrence

Property Maintenance - Deed Restrictions: Trim Trees, Bushes and/or Shrubs

Inspector Comment: Trim trees and bushes around house and especially the bush that is touching the roof of the mobile home.

[view in dashboard >](#)

6606 NEW JERSEY ST Bradenton, FL
PILATO JOSEPH A

1 Violation

 11/22/2023 @ 9:28AM



Property Maintenance - Deed Restrictions: Trim Trees, Bushes and/or Shrubs

Inspector Comment: Trim trees and bushes on property

[view in dashboard >](#)

2110 OHIO AVE Bradenton, FL
ROBERTS CLARENCE E III

1 Violation

 11/15/2023 @ 9:59AM

Property Maintenance - Deed Restrictions: Building Repairs Required

Inspector Comment: Trailer needs to be power washed, and or painted

1st Occurrence

[view in dashboard >](#)

6520 KANSAS ST Bradenton, FL
ROSS CHARLES G

3 Violations

 11/22/2023 @ 9:40AM

3rd Occurrence

Deed Restriction Article 11 & 12: Unregistered Occupant

Inspector Comment: Still have no information on person living in this home plus dogs are unregistered a non-pet friendly area

[view in dashboard >](#)

 11/15/2023 @ 10:31AM

2nd Occurrence

Deed Restriction Article 11 & 12: Unregistered Occupant

Inspector Comment: Second violation occupation is not registered with Park office as required in deed restrictions

[view in dashboard >](#)

 09/15/2023 @ 9:55AM

1st Occurrence

Deed Restriction Article 11 & 12: Unregistered Occupant

Inspector Comment: This property has has not registered with the park office and has not registered their renter with the park office

[view in dashboard >](#)

6510 KANSAS ST Bradenton, FL
SORENSEN HANNELORE

3 Violations

 11/22/2023 @ 9:37AM

Property Maintenance - Deed Restrictions: Tall Grass, Weeds, or Unsightly vegetation

Inspector Comment: Third violation please mow yard and remove unsightly vegetation

3rd Occurrence

[view in dashboard >](#)

 11/01/2023 @ 9:32AM

Property Maintenance - Deed Restrictions: Tall Grass, Weeds, or Unsightly vegetation

Inspector Comment: Property has very high grass and weeds does not appear. Anything has been done since first violation.

2nd Occurrence

[view in dashboard >](#)

 09/15/2023 @ 9:41AM

Property Maintenance - Deed Restrictions: Tall Grass, Weeds, or Unsightly vegetation

Inspector Comment: This property has overgrown grass and high weeds

1st Occurrence

[view in dashboard >](#)

6618 NEBRASKA ST Bradenton, FL
WATKINS JOHN

1 Violation

 11/15/2023 @ 10:14AM

1st Occurrence

Property Maintenance - Deed Restrictions: Building Repairs Required

Inspector Comment: Repair, paint, and fix up storage shed at rear of lot

[view in dashboard >](#)